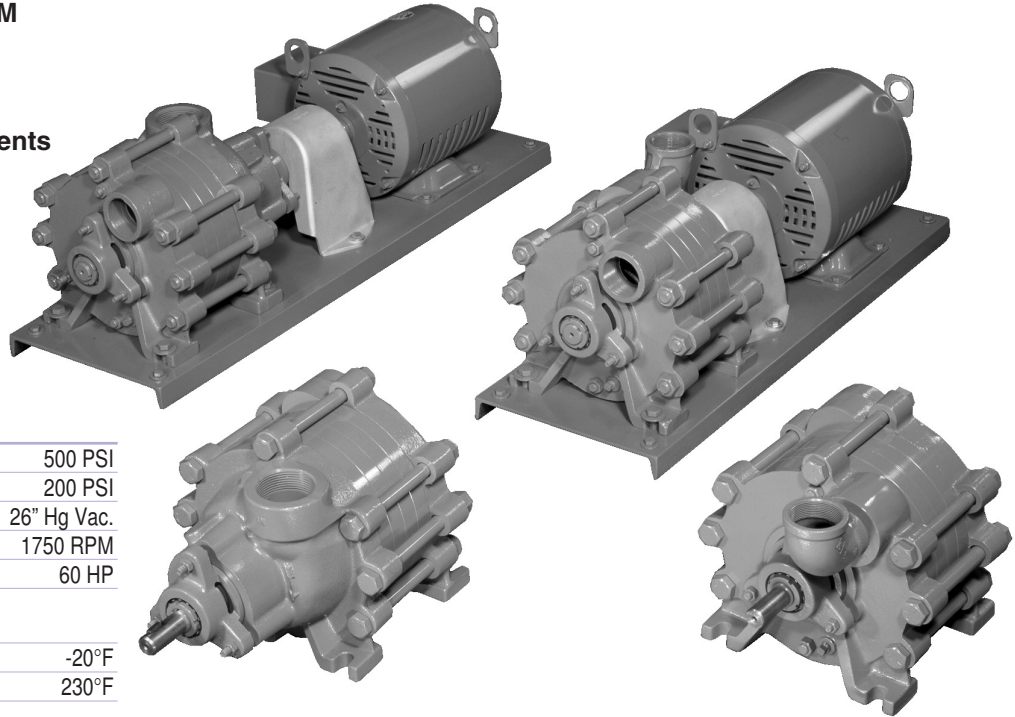

MTH PUMPS

150 • 250 • 160 • 260 • 170 • 270 Series

- Flexible Coupled
- Capacities to 150 GPM
- Heads to 1150 Feet
- Low NPSH Requirements

**LIMITATIONS**

Discharge Pressure	500 PSI
Seal Pressure*	200 PSI
Suction Pressure (Min.)	26" Hg Vac.
Speed	1750 RPM
Horsepower	60 HP

Temperature

Standard Construction	-20°F
Ceramic Seal Seat - Water	230°F
Silicon Carbide Seal Seat & External Seal Flush	250°F

*Suction Pressure Plus a Percentage of Differential Pressure

LOW NPSH**200 Series Inducer**

The 200 Series inducer style pumps are ideally suited to applications where available NPSH at the pump inlet is limited, such as boiler feed water deaerator service.

A centrifugal Francis vane impeller with low NPSH characteristics is utilized as the pump's first stage impeller, accounting for the lower inlet head requirement.

This first stage impeller is used in conjunction with a multi-vane diffuser to provide the NPSH required by the second stage regenerative turbine.

Available NPSH as low as two feet can be effectively handled with 250 • 260 • 270 Series pumps, depending on the pump model and capacity.



MTH PUMPS

401 West Main Street • Plano, IL 60545-1436
 Phone: 630-552-4115 • Fax: 630-552-3688
 Email: SALES@MTHPUMPS.COM
<http://WWW.MTHPUMPS.COM>

150 • 250 • 160 • 260 • 170 • 270 SERIES

Selection Chart

150 • 160 • 170 • 250 • 260 • 270
SERIES PUMPS

U.S. GALLONS PER MINUTE

HEAD IN FEET	U.S. GALLONS PER MINUTE													
	10	20	30	40	50	60	70	80	90	100	110	120	130	140
	Model HP	Model HP	Model HP	Model HP	Model HP	Model HP	Model HP	Model HP	Model HP	Model HP	Model HP	Model HP	Model HP	Model HP
50	*	*	151I 2	161D 2 3	161E 3	161E 3	161G 3	161G 3	171H 5	171H 5	171J 5	171J 5	171K 5	171K 5
100	*	*	151I 2	161E 3	161E 5	161F 5	161G 5	171H 5	171H 5	171J 7.5	171K 7.5	171K 7.5	172K 10	173K 15
150	*	*	161D 3	161E 5	161F 5	161G 7.5	171H 7.5	171J 7.5	171K 10	171K 10	172J 10	172K 15	173K 15	174K 15
200	*	151I 3	161D 5	161E 7.5	161G 7.5	171H 10	171J 10	171K 10	172H 10	172J 15	172K 15	173K 15	173K 15	
250	*	151I 5	151K 5	152K 7.5	161G 10	162G 10	163G 15	172H 15	172J 15	172K 15	172K 15	173K 20	173K 20	
300	*	151I 5	151L 7.5	162E 10	162F 10	162G 15	172H 15	172J 15	172K 20	172K 20	173K 20	174K 20		
350	*	161D 7.5	162D 7.5	162E 10	162G 15	172H 15	172J 20	172K 20	173J 20	173K 25	174K 25			
400	*	151L 10	162D 10	162E 15	162G 15	172H 20	172J 20	172K 20	173J 20	173K 25	174K 25			
450	151I 7.5	152I 7.5	152K 10	162F 15	162G 15	172J 20	173H 20	173J 25	173K 25	174K 30				
500	151I 7.5	152I 7.5	163D 10	163E 15	163G 20	164G 20	173J 25	174J 25	174K 30	174K 30				
550	161D 10	162D 10	162E 15	163E 15	163G 20	164G 20	173J 25	173K 30	174K 30					
600	161D 10	162D 10	152L 15	162G 20	163G 20	164G 25	173K 30	174J 30	174K 30					
700	152I 10	162D 15	163E 20	164E 20	164G 25	174H 30	174J 40	174K 40						
800	152I 10	163D 15	163E 20	164F 25	164G 30	174J 40								
900	152I 15	163D 15	164E 25	164G 30	174J 40									
1000	152I 15	163D 20	164E 25	164G 40										
1100	153I 20	164D 20	154L 30											

NOTES

Selections based on cold water flooded suction
 1.0 S.G. Open Drip proof Motor.
 Consult individual pump curve for final selection.
 *Refer to 140 • 240 • 180 • 280 Series Selection Chart



MTH PUMPS

401 West Main Street • Plano, IL 60545-1436
 Phone: 630-552-4115 • Fax: 630-552-3688
 Email: SALES@MTHPUMPS.COM
 http://WWW.MTHPUMPS.COM

150 • 250 • 160 • 260 • 170 • 270 SERIES

Performance Curves

150I & 250I*

1750 RPM

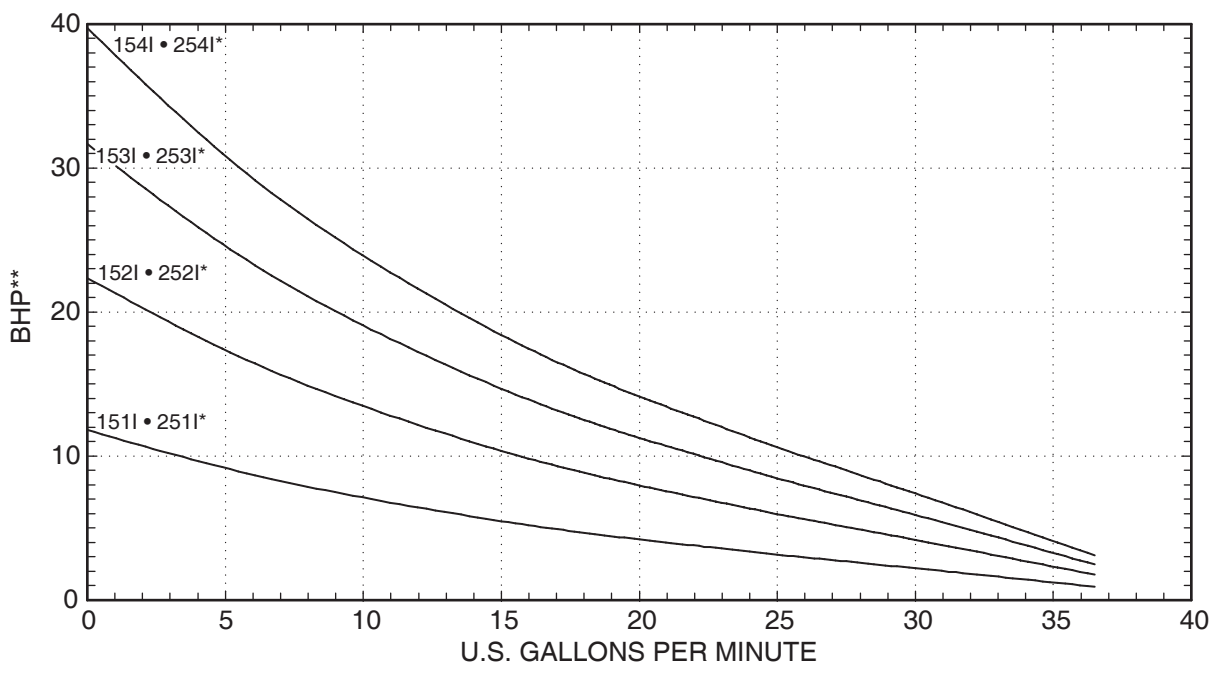
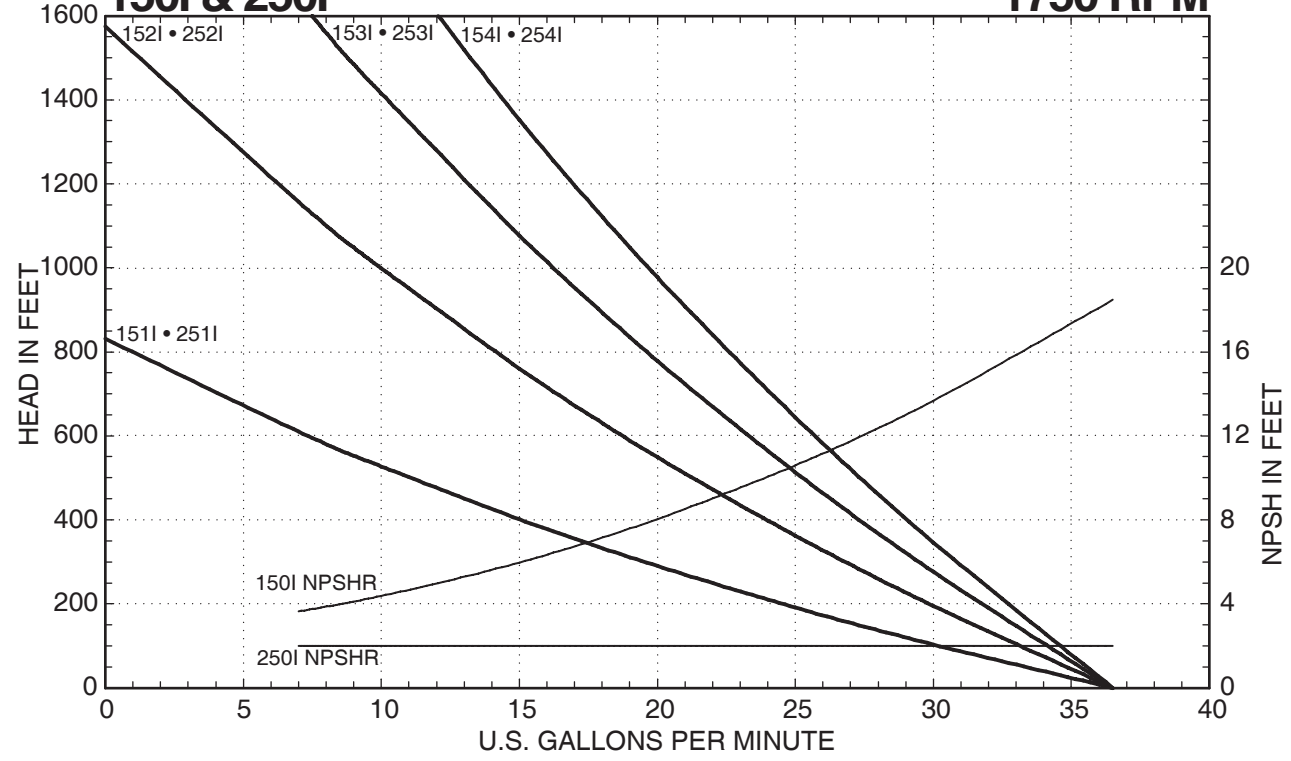

150 • 160 • 170 • 250 • 260 • 270
SERIES PUMPS

NOTES

Do not exceed 1150 feet TDH with 1.0 S.G. fluids
 Consult factory for operation below 4 GPM
 *Add 1 horsepower for 250 Series models
 **Horsepower is valid for 1.0 specific gravity fluids only



MTH PUMPS

401 West Main Street • Plano, IL 60545-1436
 Phone: 630-552-4115 • Fax: 630-552-3688
 Email: SALES@MTHPUMPS.COM
 http://WWW.MTHPUMPS.COM

150 • 250 • 160 • 260 • 170 • 270 SERIES
Performance Curves

150 • 160 • 170 • 250 • 260 • 270
 SERIES PUMPS

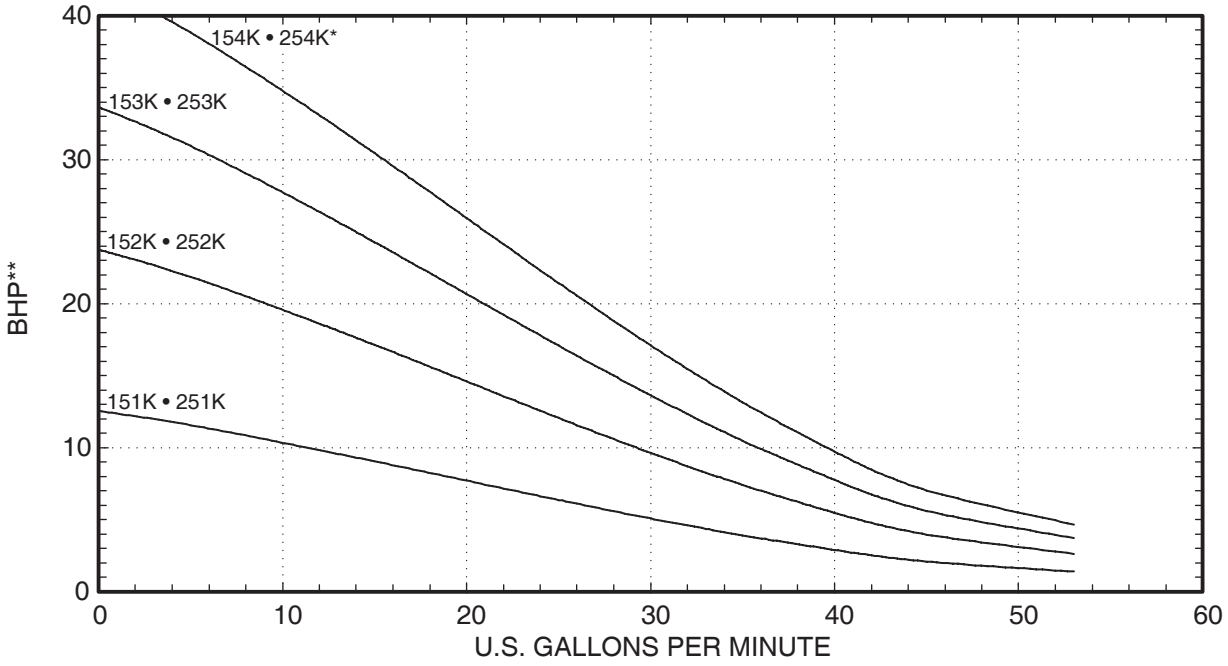
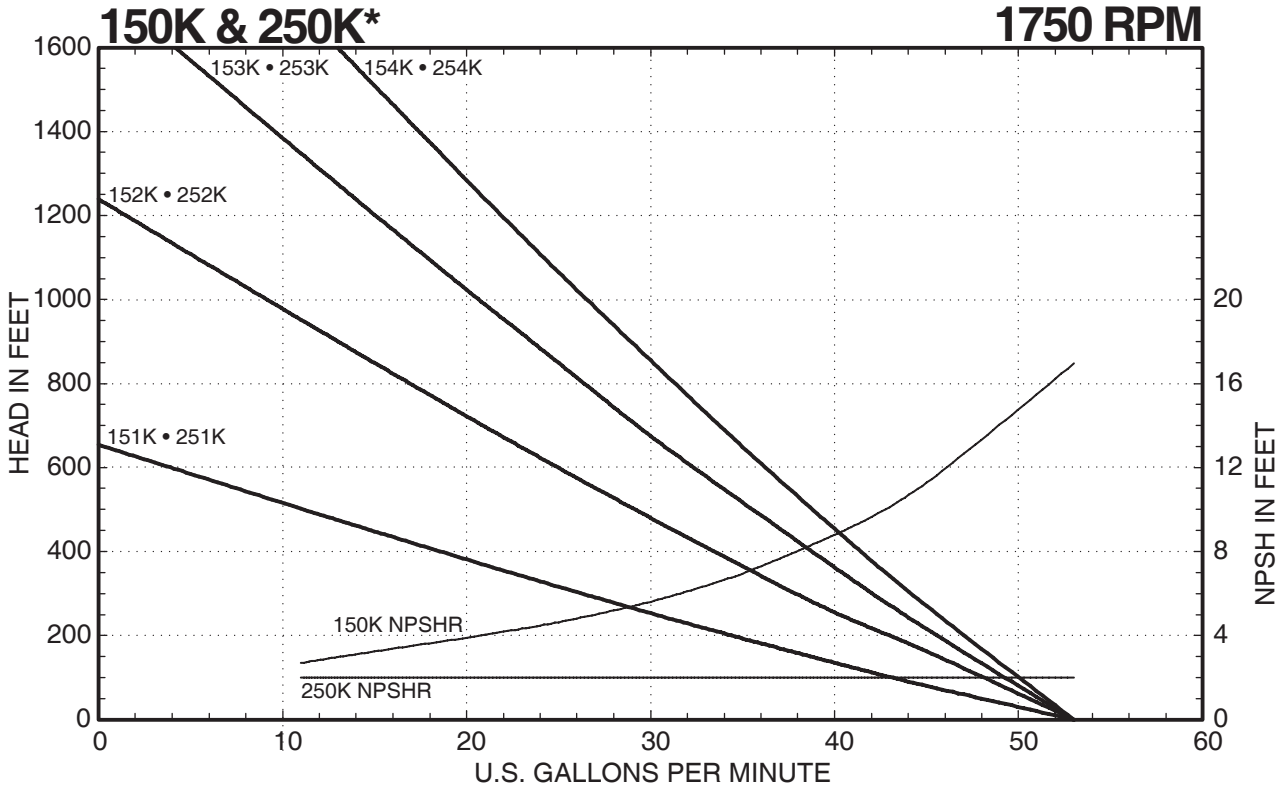

NOTES
 Do not exceed 1150 feet TDH with 1.0 S.G. fluids
 Consult factory for operation below 6 GPM
 *Add 1 horsepower for 250 Series models
 **Horsepower is valid for 1.0 specific gravity fluids only



MTH PUMPS
 401 West Main Street • Plano, IL 60545-1436
 Phone: 630-552-4115 • Fax: 630-552-3688
 Email: SALES@MTHPUMPS.COM
 http://WWW.MTHPUMPS.COM

150 • 250 • 160 • 260 • 170 • 270 SERIES

Performance Curves

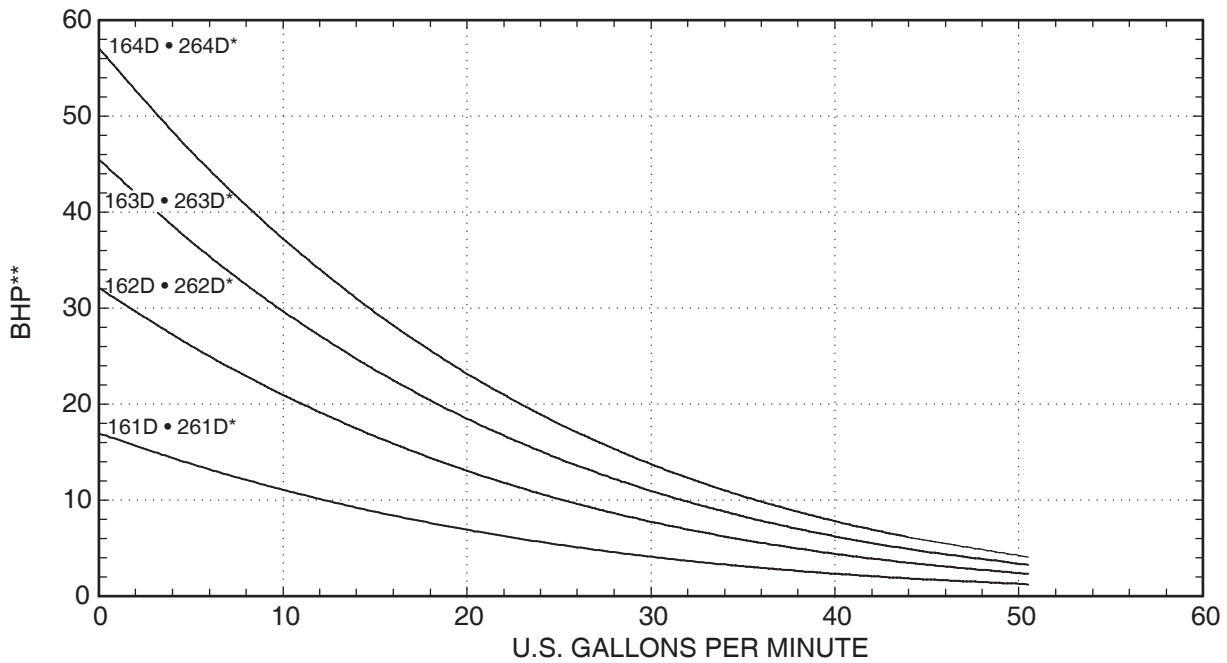
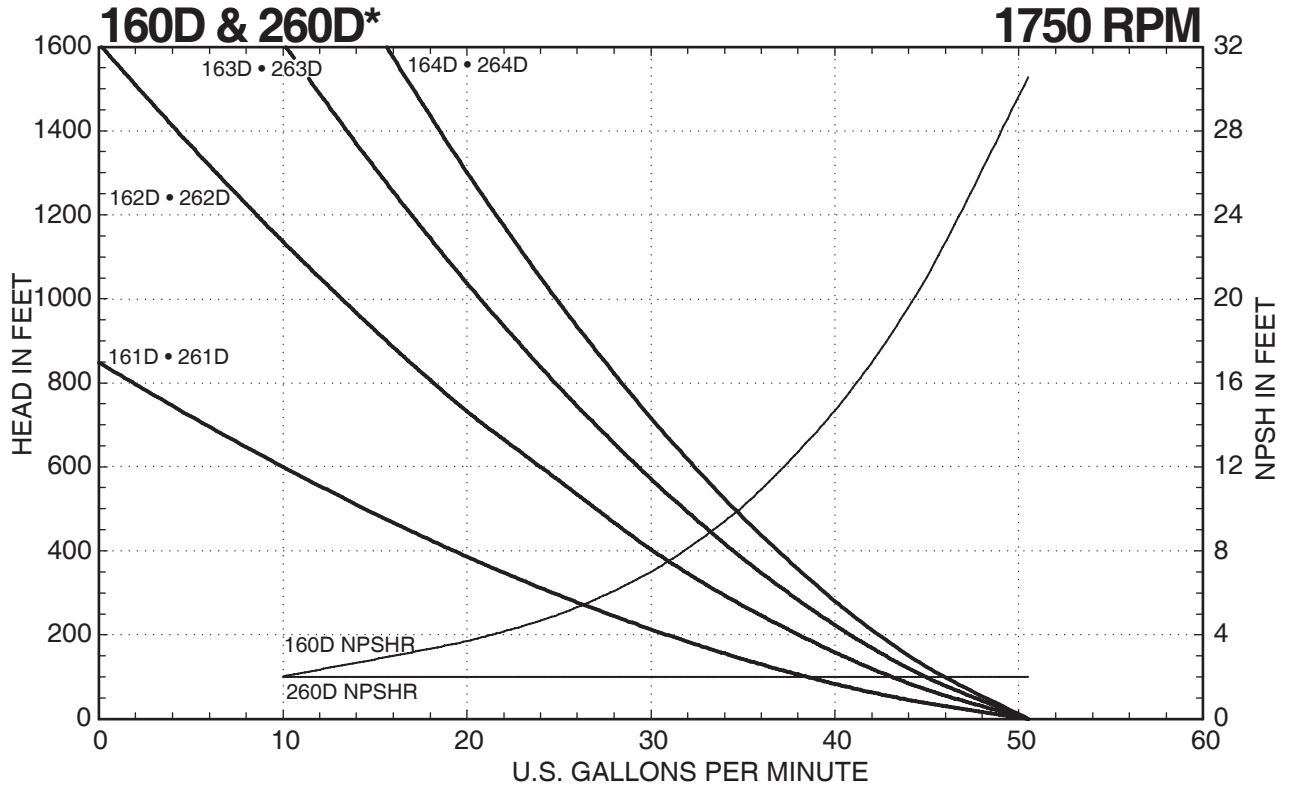

NOTES

Do not exceed 1150 feet TDH with 1.0 S.G. fluids
 Consult factory for operation below 7 GPM
 *Add 1 horsepower for 260 Series models
 **Horsepower is valid for 1.0 specific gravity fluids only



401 West Main Street • Plano, IL 60545-1436
 Phone: 630-552-4115 • Fax: 630-552-3688
 Email: SALES@MTHPUMPS.COM
<http://WWW.MTHPUMPS.COM>

150 • 160 • 170 • 250 • 260 • 270 SERIES PUMPS

150 • 250 • 160 • 260 • 170 • 270 SERIES
Performance Curves

150L & 250L*

1750 RPM

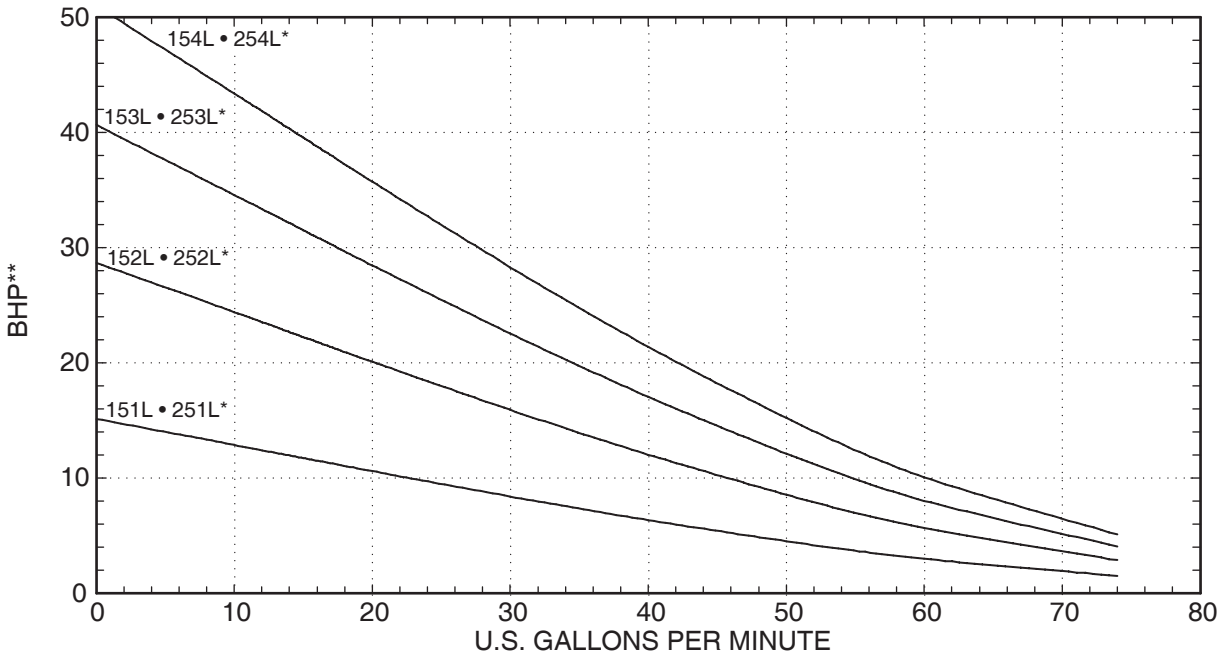
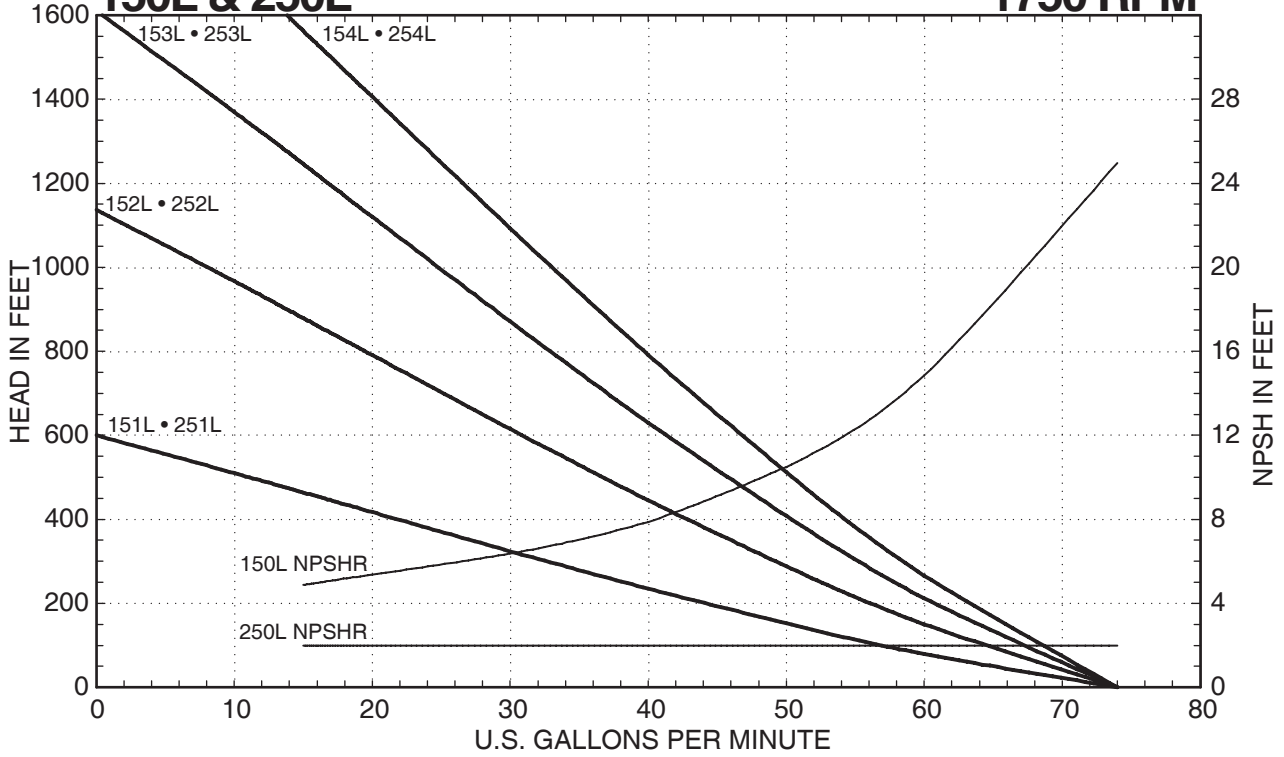

NOTES

Do not exceed 1150 feet TDH with 1.0 S.G. fluids
 Consult factory for operation below 8 GPM
 *Add 1 horsepower for 250 Series models
 **Horsepower is valid for 1.0 specific gravity fluids only



MTH PUMPS

401 West Main Street • Plano, IL 60545-1436
 Phone: 630-552-4115 • Fax: 630-552-3688
 Email: SALES@MTHPUMPS.COM
 http://WWW.MTHPUMPS.COM

150 • 160 • 170 • 250 • 260 • 270
 SERIES PUMPS

150 • 250 • 160 • 260 • 170 • 270 SERIES

Performance Curves

160E & 260E*

1750 RPM

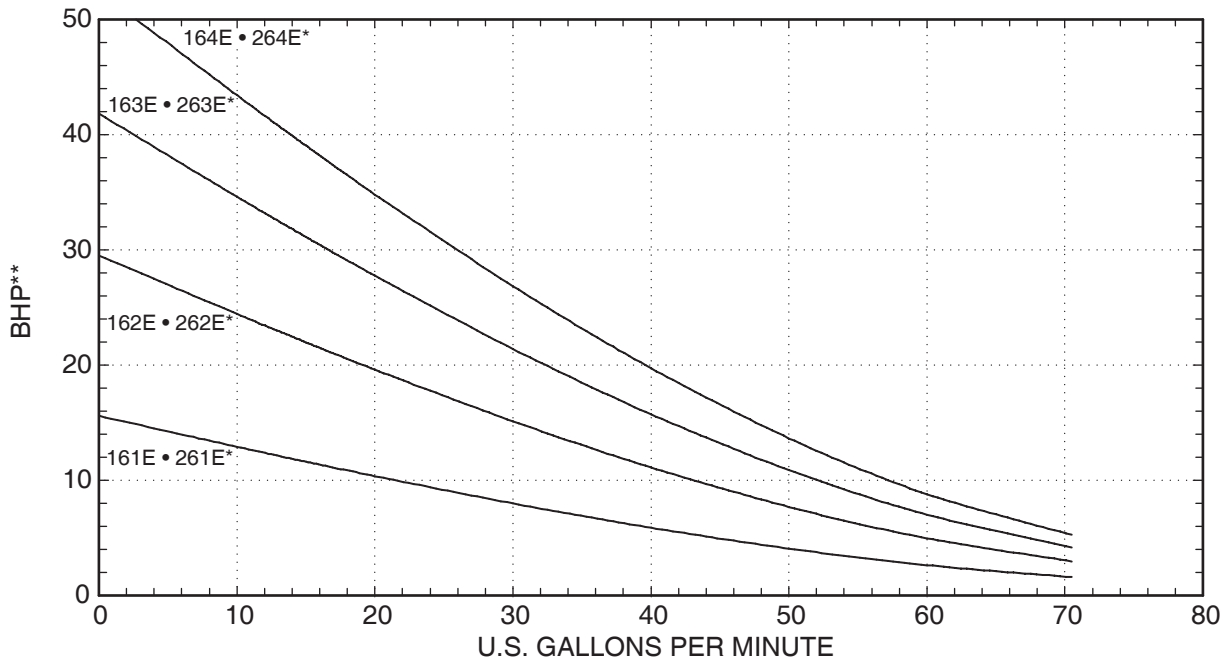
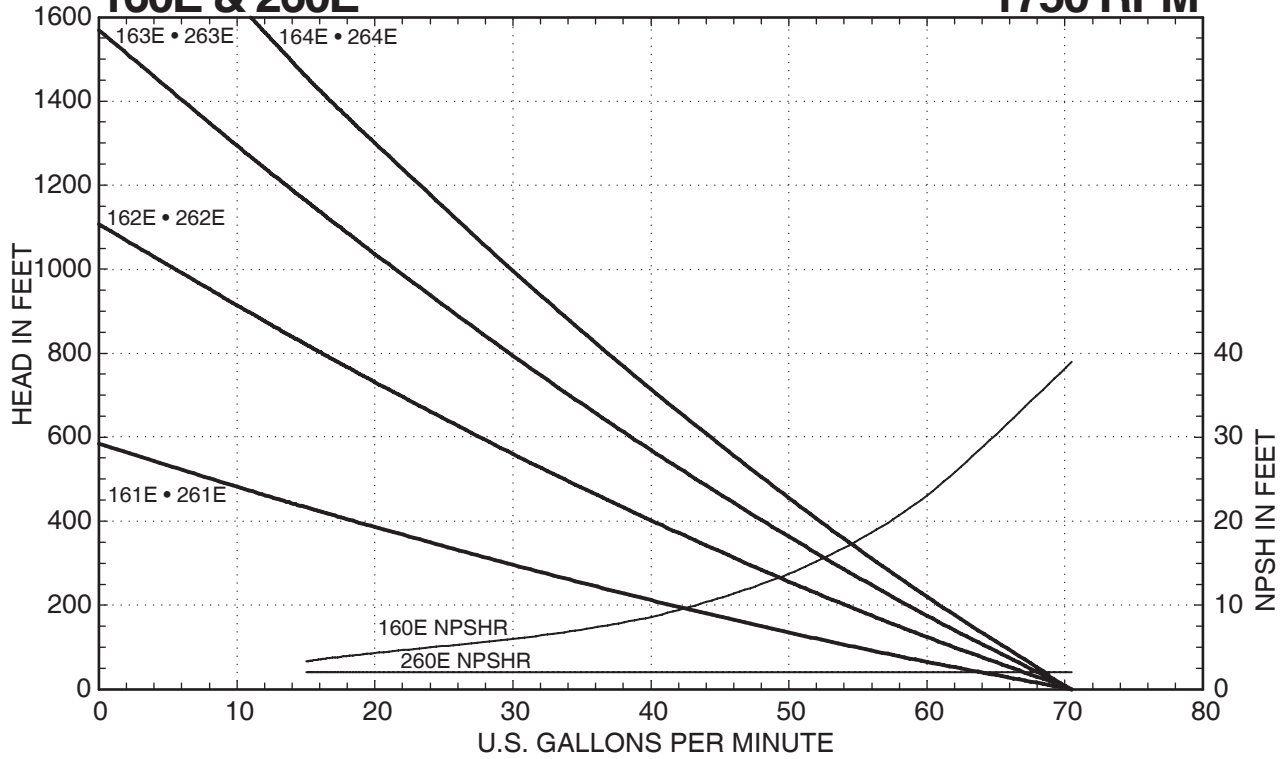

NOTES

Do not exceed 1150 feet TDH with 1.0 S.G. fluids
 Consult factory for operation below 8 GPM
 *Add 1 horsepower for 260 Series models
 **Horsepower is valid for 1.0 specific gravity fluids only



401 West Main Street • Plano, IL 60545-1436
 Phone: 630-552-4115 • Fax: 630-552-3688
 Email: SALES@MTHPUMPS.COM
 http://WWW.MTHPUMPS.COM

150 • 160 • 170 • 250 • 260 • 270 SERIES PUMPS

150 • 250 • 160 • 260 • 170 • 270 SERIES
Performance Curves

160F & 260F*

1750 RPM

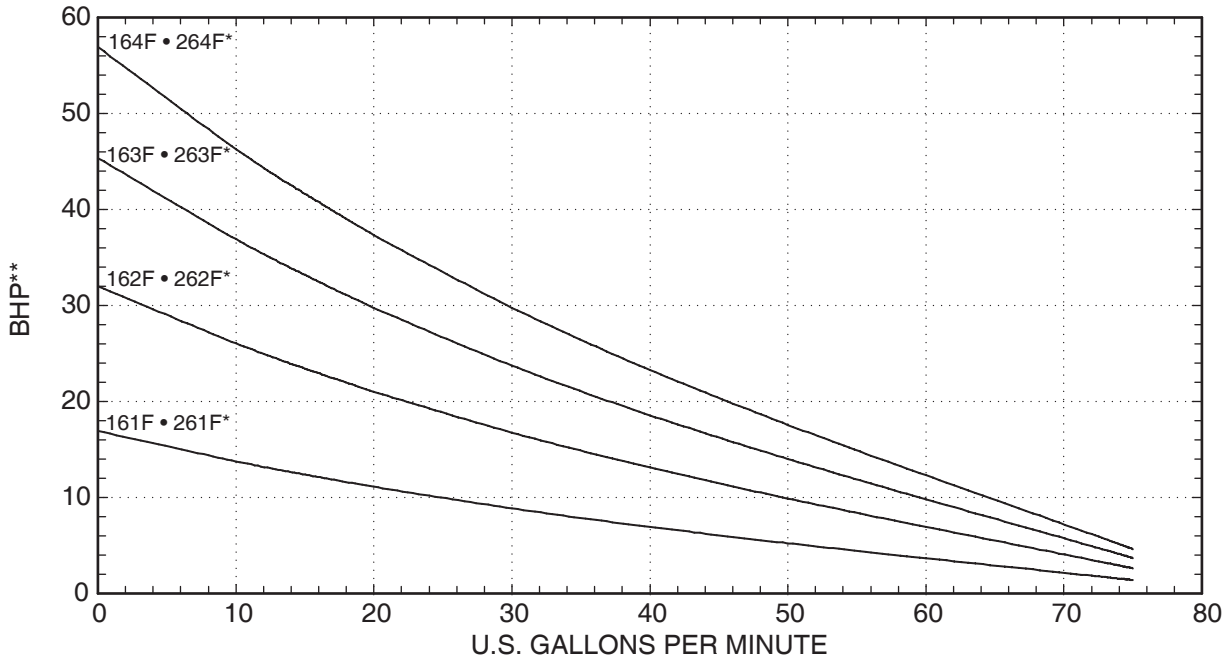
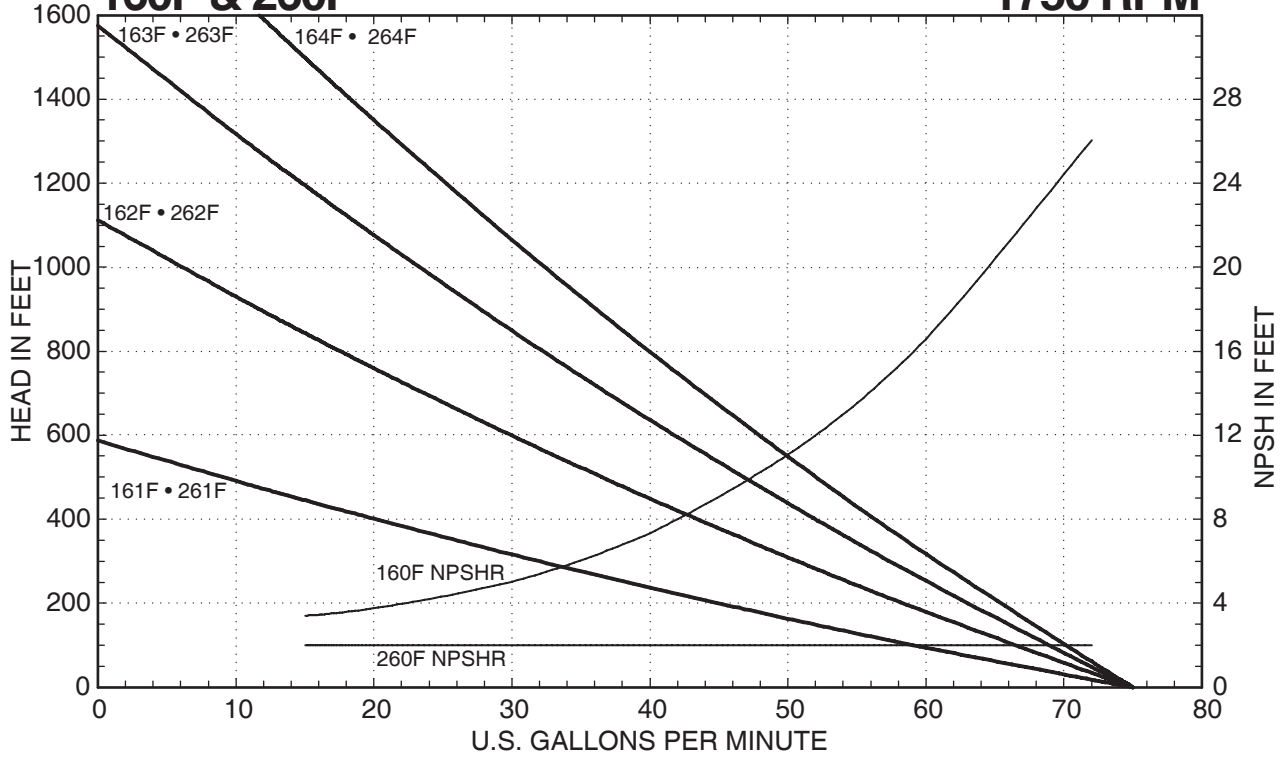

NOTES

Do not exceed 1150 feet TDH with 1.0 S.G. fluids
 Consult factory for operation below 10 GPM
 *Add 1 horsepower for 260 Series models
 **Horsepower is valid for 1.0 specific gravity fluids only



MTH PUMPS

401 West Main Street • Plano, IL 60545-1436
 Phone: 630-552-4115 • Fax: 630-552-3688
 Email: SALES@MTHPUMPS.COM
 http://WWW.MTHPUMPS.COM

150 • 160 • 170 • 250 • 260 • 270
 SERIES PUMPS

150 • 250 • 160 • 260 • 170 • 270 SERIES

Performance Curves

160G & 260G*

1750 RPM

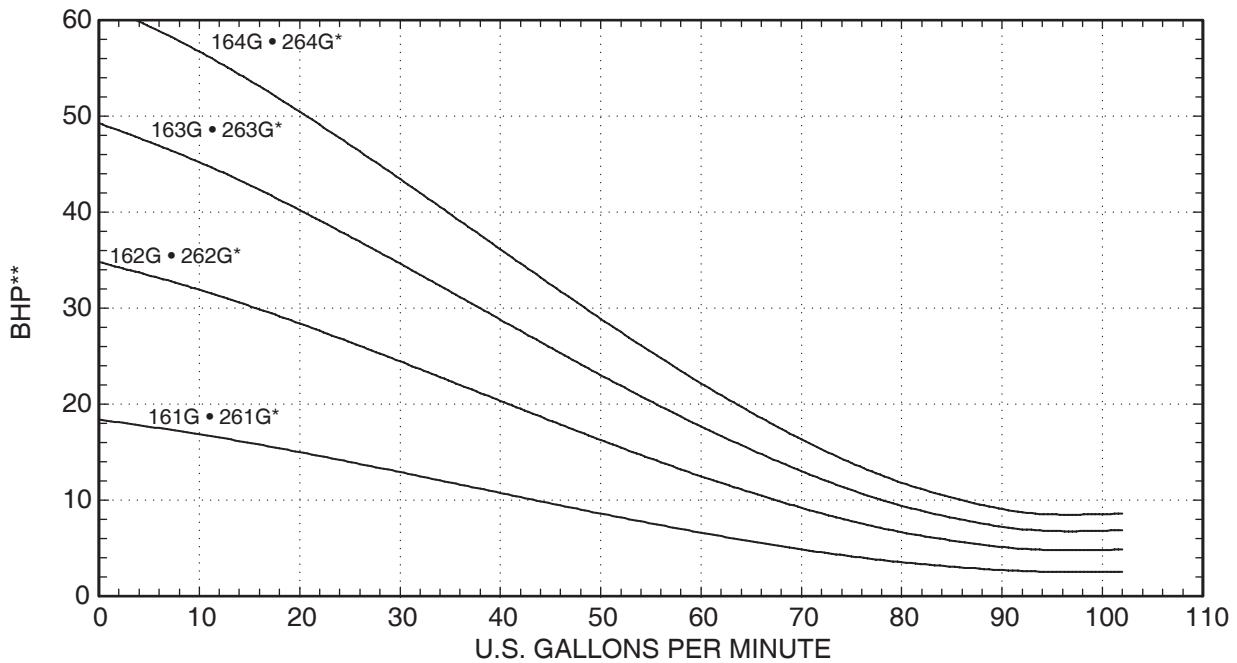
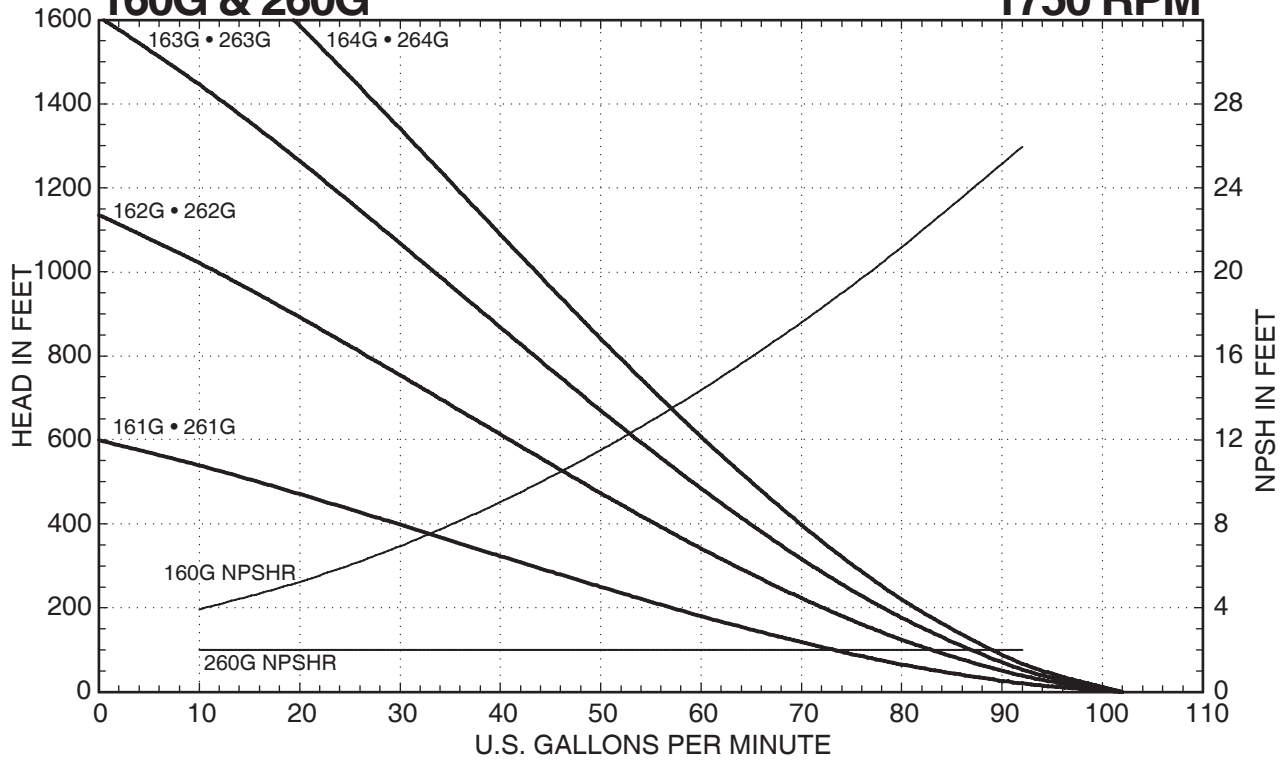

NOTES

Do not exceed 1150 feet TDH with 1.0 S.G. fluids
 Consult factory for operation below 15 GPM
 *Add 1 horsepower for 260 Series models
 **Horsepower is valid for 1.0 specific gravity fluids only



401 West Main Street • Plano, IL 60545-1436
 Phone: 630-552-4115 • Fax: 630-552-3688
 Email: SALES@MTHPUMPS.COM
<http://WWW.MTHPUMPS.COM>

150 • 160 • 170 • 250 • 260 • 270
 SERIES PUMPS

150 • 250 • 160 • 260 • 170 • 270 SERIES
Performance Curves

170H & 270H*

1750 RPM

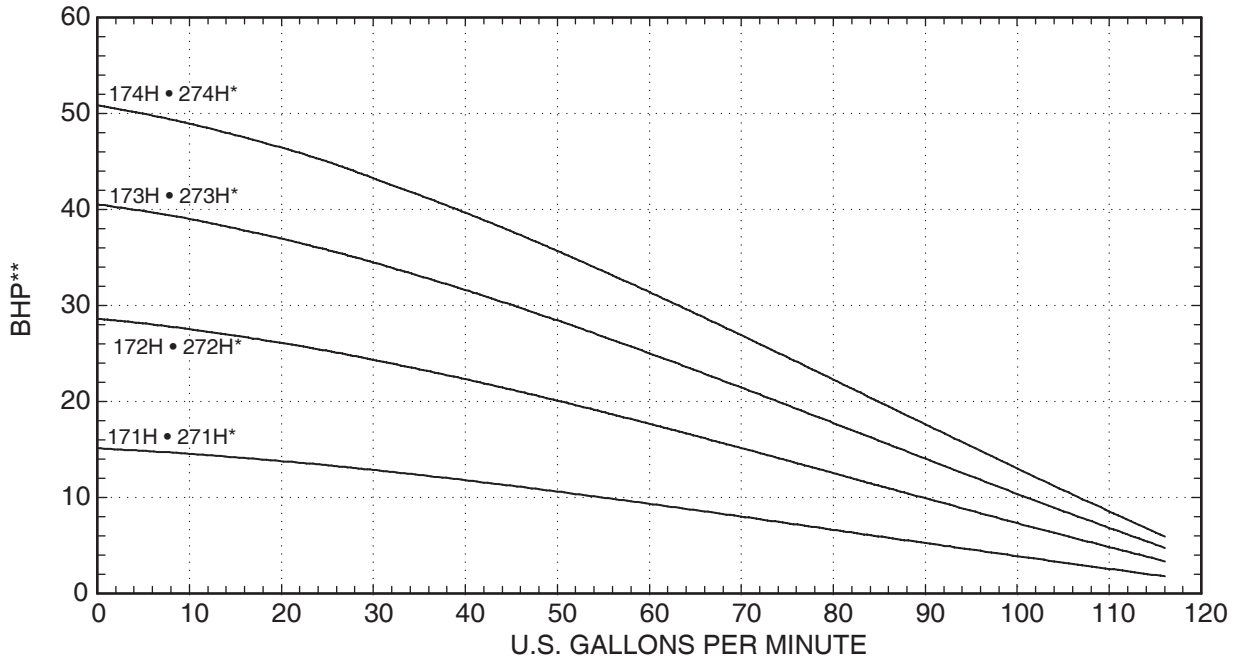
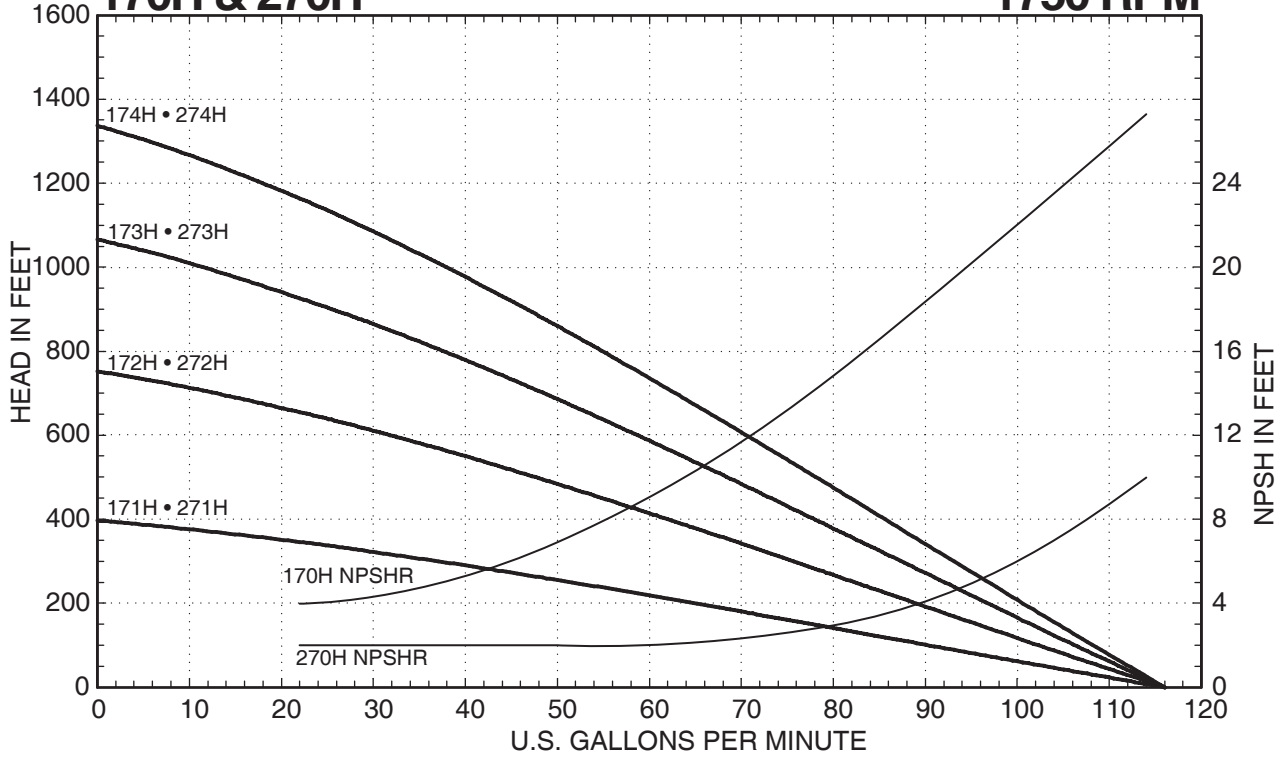

NOTES

Do not exceed 1150 feet TDH with 1.0 S.G. fluids
 Consult factory for operation below 15 GPM
 *Add 1 horsepower for 270 Series models
 **Horsepower is valid for 1.0 specific gravity fluids only



MTH PUMPS
 401 West Main Street • Plano, IL 60545-1436
 Phone: 630-552-4115 • Fax: 630-552-3688
 Email: SALES@MTHPUMPS.COM
 http://WWW.MTHPUMPS.COM

150 • 160 • 170 • 250 • 260 • 270
SERIES PUMPS

150 • 250 • 160 • 260 • 170 • 270 SERIES

Performance Curves

170J & 270J*

1750 RPM

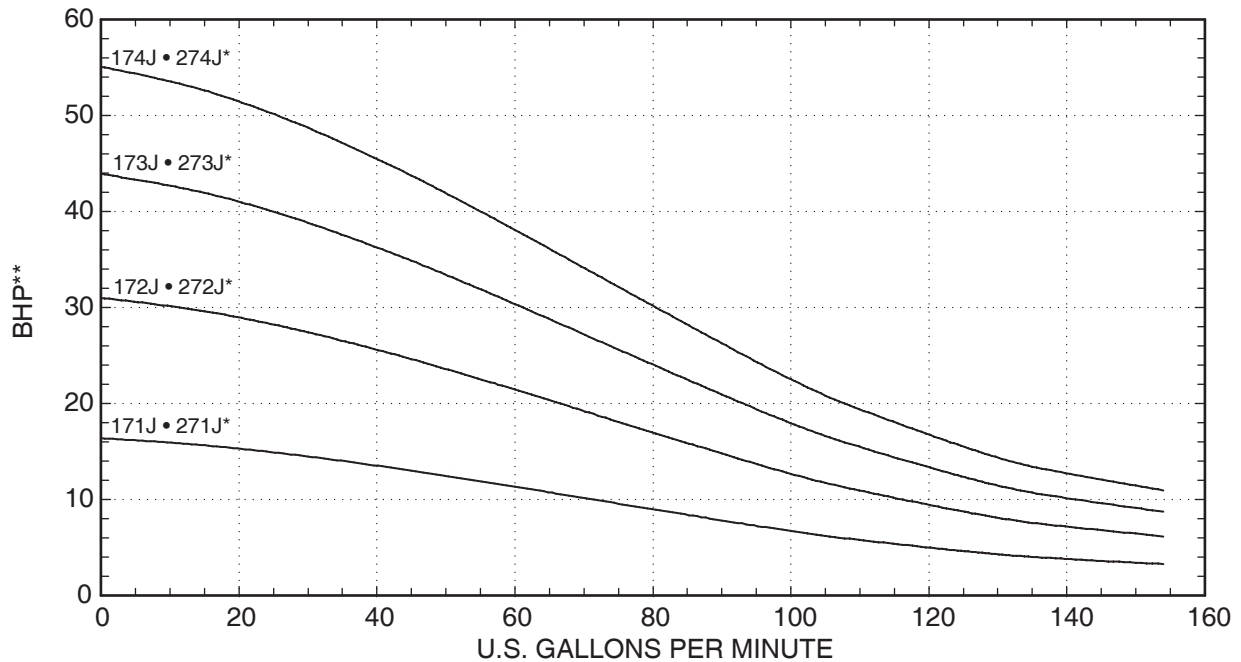
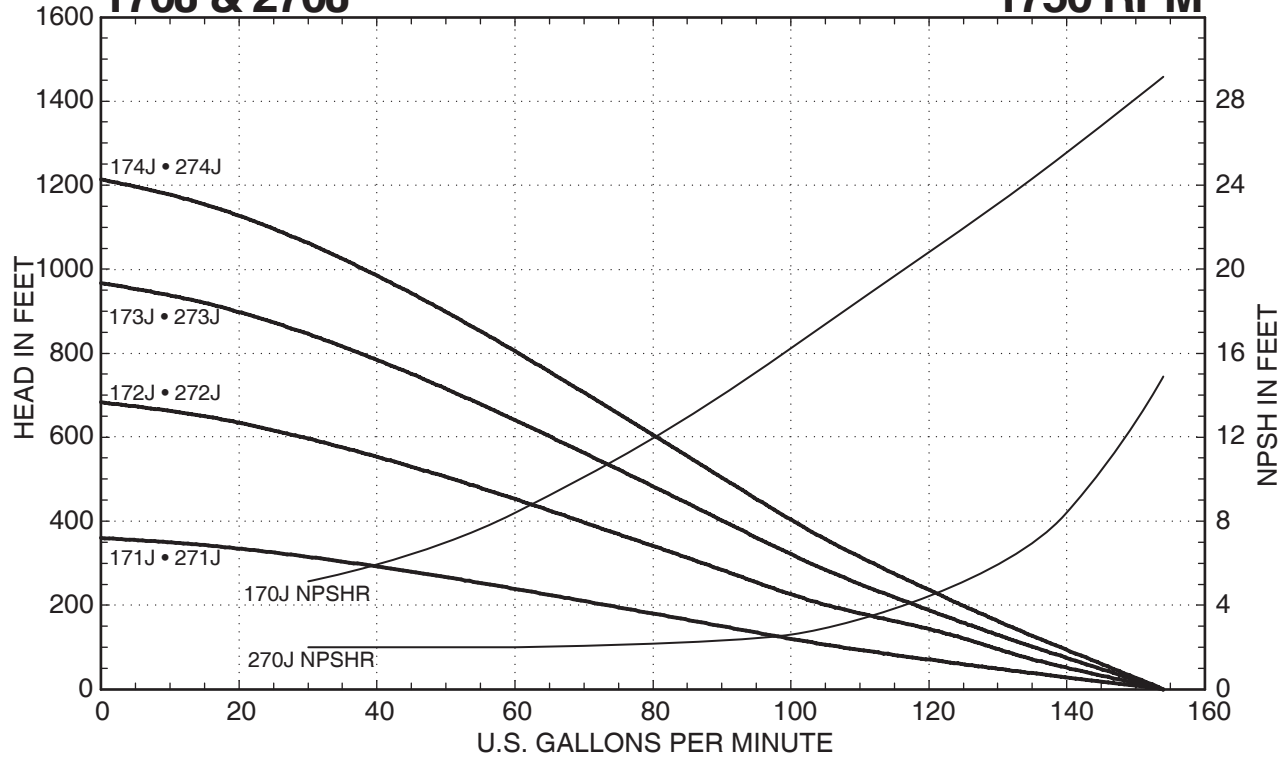

NOTES

Do not exceed 1150 feet TDH with 1.0 S.G. fluids
 Consult factory for operation below 18 GPM
 *Add 1 horsepower for 270 Series models
 **Horsepower is valid for 1.0 specific gravity fluids only



401 West Main Street • Plano, IL 60545-1436
 Phone: 630-552-4115 • Fax: 630-552-3688
 Email: SALES@MTHPUMPS.COM
 http://WWW.MTHPUMPS.COM

150 • 160 • 170 • 250 • 260 • 270
 SERIES PUMPS

150 • 250 • 160 • 260 • 170 • 270 SERIES
Performance Curves

170K & 270K*

1750 RPM

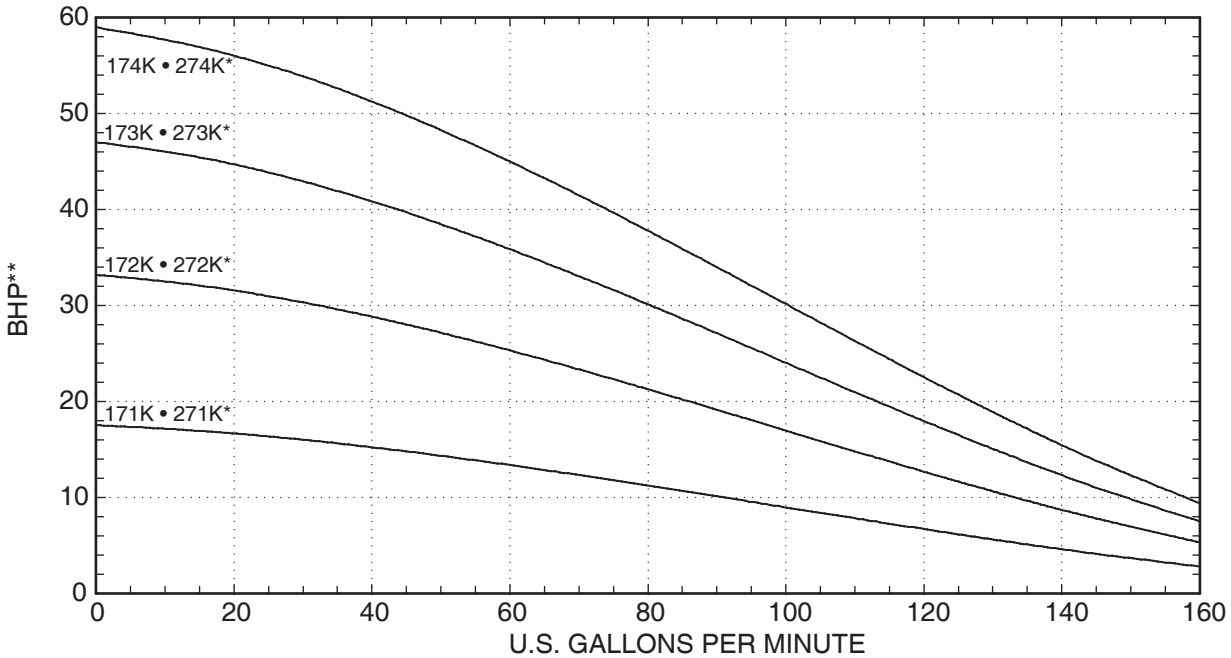
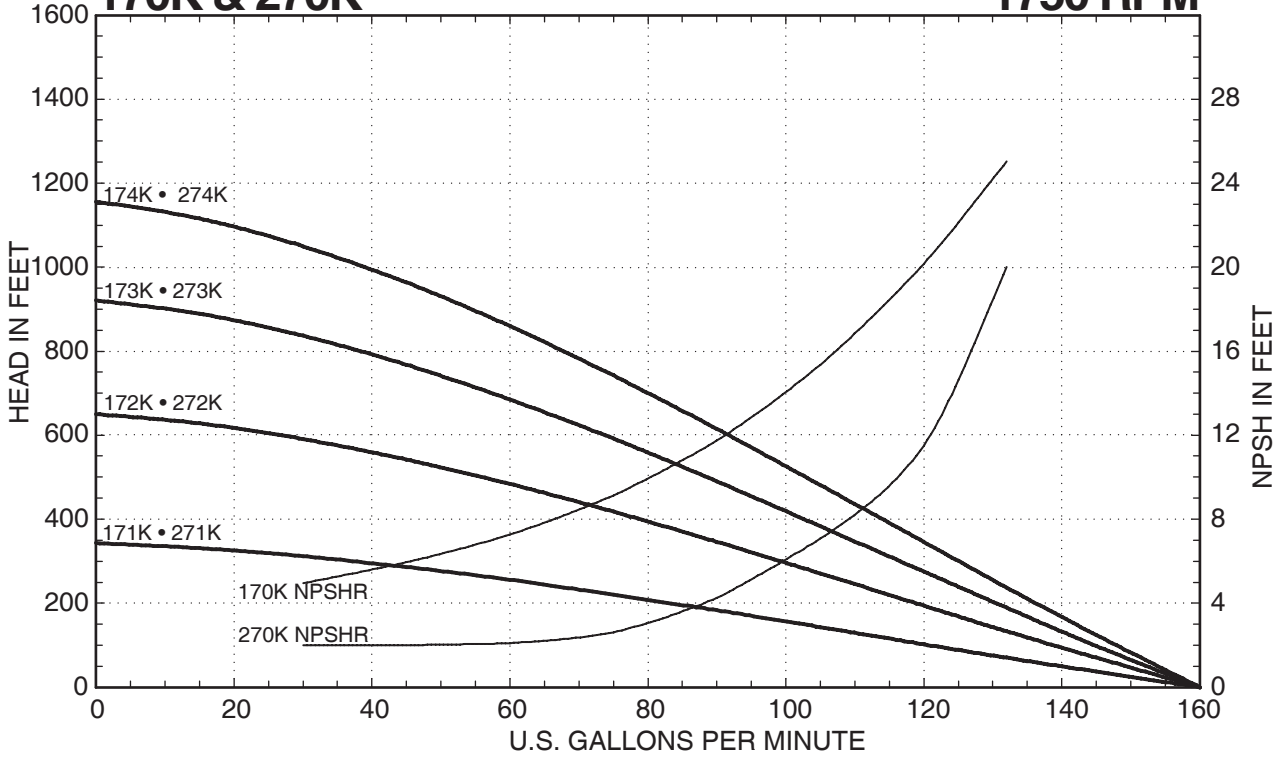

NOTES

Do not exceed 1150 feet TDH with 1.0 S.G. fluids
 Consult factory for operation below 20 GPM
 *Add 1 horsepower for 270 Series models
 **Horsepower is valid for 1.0 specific gravity fluids only



401 West Main Street • Plano, IL 60545-1436
 Phone: 630-552-4115 • Fax: 630-552-3688
 Email: SALES@MTHPUMPS.COM
 http://WWW.MTHPUMPS.COM

150 • 160 • 170 • 250 • 260 • 270
 SERIES PUMPS

150 • 250 • 160 • 260 • 170 • 270 SERIES

Dimensions

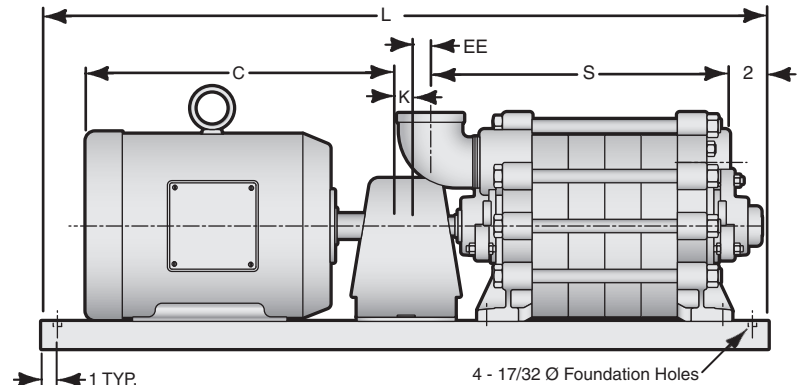
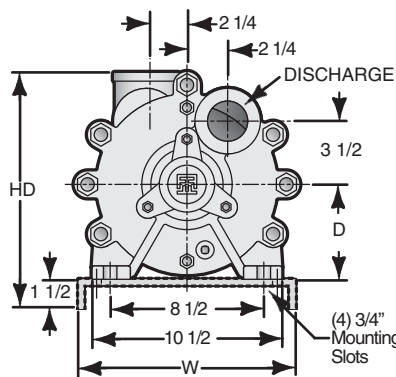
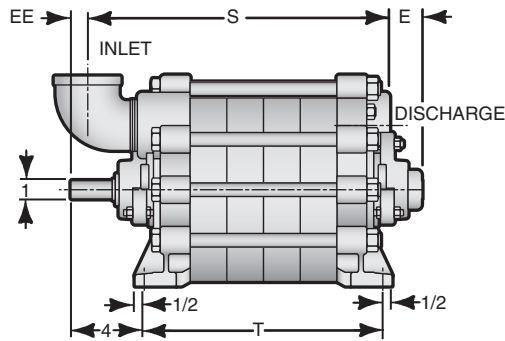

Pump Only Dimensions

PUMP SERIES	INLET	DISCHARGE	E	EE	S	T
151 • 161	2" NPT	2" NPT	1 13/16	1 5/16	10 1/8	7
152 • 162	2" NPT	2" NPT	1 13/16	1 5/16	12 1/8	9
153 • 163	2" NPT	2" NPT	1 13/16	1 5/16	14 1/8	11
154 • 164	2" NPT	2" NPT	1 13/16	1 5/16	16 1/8	13
171	2 1/2" NPT	2 1/2" NPT	1 15/16	1	12 1/2	9
172	2 1/2" NPT	2 1/2" NPT	1 15/16	1	16 1/2	13
173	2 1/2" NPT	2 1/2" NPT	1 15/16	1	20 1/2	17
174	2 1/2" NPT	2 1/2" NPT	1 15/16	1	24 1/2	21

ROTATION: Clockwise when viewed from driver end.

150 • 160 Series Flex Coupled Pump Dimensions

FRAME	CPLG	ALL 150 • 160 MODELS					MODEL 151 • 161		MODEL 152 • 162		MODEL 153 • 163		MODEL 154 • 164	
		D	K	HD	W	C	L	S	L	S	L	S	L	S
143T	4J	5 1/4	5/8	12 1/2	12	13	28	10 1/8	30	12 1/8	32	14 1/8	35	16 1/8
145T	4J	5 1/4	5/8	12 1/2	12	14	28	10 1/8	30	12 1/8	32	14 1/8	35	16 1/8
182T	5J	5 1/4	3/4	12 1/2	12	16	30	10 1/8	32	12 1/8	35	14 1/8	40	16 1/8
184T	5J	5 1/4	3/4	12 1/2	12	17	30	10 1/8	32	12 1/8	35	14 1/8	40	16 1/8
213T	6J	5 1/4	7/8	12 1/2	12	19	35	10 1/8	35	12 1/8	40	14 1/8	40	16 1/8
215T	6J	5 1/4	7/8	12 1/2	12	20	35	10 1/8	35	12 1/8	40	14 1/8	40	16 1/8
254T	7S	6 1/4	1	13 1/2	15	24	40	10 1/8	40	12 1/8	45	14 1/8	45	16 1/8
256T	8S	6 1/4	1 1/8	13 1/2	15	25	40	10 1/8	40	12 1/8	45	14 1/8	45	16 1/8
284T	8S	7	1 1/8	14 1/4	15	25	40	10 1/8	45	12 1/8	45	14 1/8	50	16 1/8
286T	8S	7	1 1/8	14 1/4	15	28	40	10 1/8	45	12 1/8	45	14 1/8	50	16 1/8
324T	8S	8	1 1/8	15 1/4	18	29	45	10 1/8	45	12 1/8	50	14 1/8	50	16 1/8
326T	8S	8	1 1/8	15 1/4	18	31	45	10 1/8	45	12 1/8	50	14 1/8	50	16 1/8
364T	8S	9	1 1/8	16 1/4	18	32	50	10 1/8	50	12 1/8	50	14 1/8	55	16 1/8

170 Series Flex Coupled Pump Dimensions

FRAME	CPLG	ALL 170 MODELS					MODEL 171		MODEL 172		MODEL 173		MODEL 174	
		D	K	HD	W	C	L	S	L	S	L	S	L	S
143T	4J	5 1/4	5/8	13 1/4	12	13	30	12 1/2	33	16 1/2	40	20 1/2	45	24 1/2
145T	4J	5 1/4	5/8	13 1/4	12	14	30	12 1/2	33	16 1/2	40	20 1/2	45	24 1/2
182T	5J	5 1/4	3/4	13 1/4	12	16	32	12 1/2	38	16 1/2	40	20 1/2	45	24 1/2
184T	5J	5 1/4	3/4	13 1/4	12	17	32	12 1/2	38	16 1/2	40	20 1/2	45	24 1/2
213T	6J	5 1/4	7/8	13 1/4	12	19	35	12 1/2	40	16 1/2	45	20 1/2	50	24 1/2
215T	6J	5 1/4	7/8	13 1/4	12	20	35	12 1/2	40	16 1/2	45	20 1/2	50	24 1/2
254T	7S	6 1/4	1	14 1/4	15	24	40	12 1/2	45	16 1/2	50	20 1/2	55	24 1/2
256T	8S	6 1/4	1 1/8	14 1/4	15	25	40	12 1/2	45	16 1/2	50	20 1/2	55	24 1/2
284T	8S	7	1 1/8	15	15	25	45	12 1/2	45	16 1/2	50	20 1/2	55	24 1/2
286T	8S	7	1 1/8	15	15	28	45	12 1/2	45	16 1/2	50	20 1/2	55	24 1/2
324T	8S	8	1 1/8	16	18	29	45	12 1/2	50	16 1/2	55	20 1/2	60	24 1/2
326T	8S	8	1 1/8	16	18	31	45	12 1/2	50	16 1/2	55	20 1/2	60	24 1/2
364T	8S	9	1 1/8	17	18	32	50	12 1/2	50	16 1/2	55	20 1/2	60	24 1/2

NOTES

All dimensions in inches. May vary $\pm 1/4$ inches.

*C Dimension varies depending on motor enclosure type. Max Dimension Listed

Not for construction purposes unless certified.

ROTATION: Clockwise when viewed from driver end.

401 West Main Street • Plano, IL 60545-1436
 Phone: 630-552-4115 • Fax: 630-552-3688
 Email: SALES@MTHPUMPS.COM
 http://WWW.MTHPUMPS.COM

150 • 250 • 160 • 260 • 170 • 270 SERIES

Dimensions

150 • 160 • 170 • 250 • 260 • 270 SERIES PUMPS

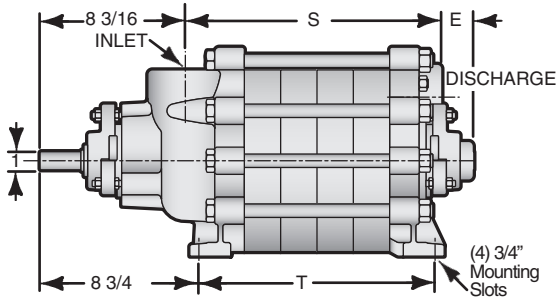

Pump Only Dimensions

PUMP SERIES	INLET	DISCHARGE	E	S	T
251 • 261	2 1/2" NPT	2" NPT	1 13/16	8	7
252 • 262	2 1/2" NPT	2" NPT	1 13/16	10	9
253 • 263	2 1/2" NPT	2" NPT	1 13/16	12	11
254 • 264	2 1/2" NPT	2" NPT	1 13/16	14	13
271	2 1/2" NPT	2 1/2" NPT	1 15/16	10	9
272	2 1/2" NPT	2 1/2" NPT	1 15/16	14	13
273	2 1/2" NPT	2 1/2" NPT	1 15/16	18	17
274	2 1/2" NPT	2 1/2" NPT	1 15/16	22	21

ROTATION: Clockwise when viewed from driver end.

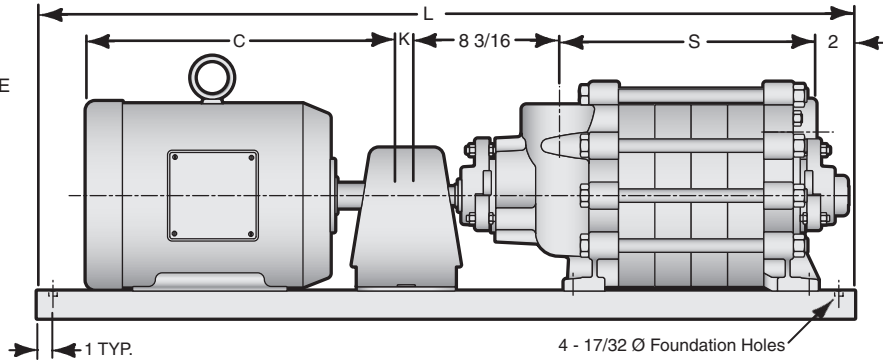
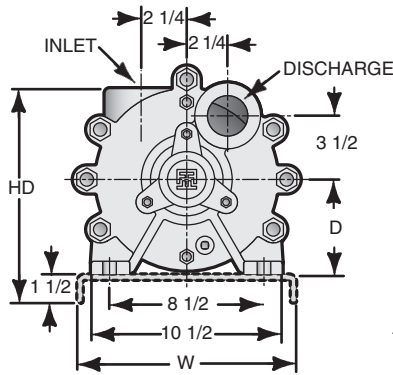

250 • 260 Series Flex Coupled Pump Dimensions

FRAME	CPLG	ALL 250 • 260 MODELS					MODEL 251 • 261		MODEL 252 • 262		MODEL 253 • 263		MODEL 254 • 264	
		D	K	HD	W	C	L	S	L	S	L	S	L	S
143T	4J	5 1/4	5/8	11 3/4	12	13	35	8	35	10	-	-	-	-
145T	4J	5 1/4	5/8	11 3/4	12	14	35	8	35	10	-	-	-	-
182T	5J	5 1/4	3/4	11 3/4	12	16	35	8	40	10	40	12	45	14
184T	5J	5 1/4	3/4	11 3/4	12	17	35	8	40	10	40	12	45	14
213T	6J	5 1/4	7/8	11 3/4	12	19	40	8	40	10	45	12	45	14
215T	6J	5 1/4	7/8	11 3/4	12	20	40	8	40	10	45	12	45	14
254T	7S	6 1/4	1	12 3/4	15	24	45	8	45	10	50	12	50	14
256T	8S	6 1/4	1 1/8	12 3/4	15	25	45	8	45	10	50	12	50	14
284T	8S	7	1 1/8	13 1/2	15	25	45	8	50	10	50	12	50	14
286T	8S	7	1 1/8	13 1/2	15	28	45	8	50	10	50	12	50	14
324T	8S	8	1 1/8	14 1/2	18	29	50	8	50	10	55	12	55	14
326T	8S	8	1 1/8	14 1/2	18	31	50	8	50	10	55	12	55	14
364T	8S	9	1 1/8	15 1/2	18	32	50	8	50	10	55	12	55	14

270 Series Flex Coupled Pump Dimensions

FRAME	CPLG	ALL 270 MODELS					MODEL 271		MODEL 272		MODEL 273		MODEL 274	
		D	K	HD	W	C	L	S	L	S	L	S	L	S
143T	4J	5 1/4	5/8	11 3/4	12	13	35	10	40	14	-	-	-	-
145T	4J	5 1/4	5/8	11 3/4	12	14	35	10	40	14	-	-	-	-
182T	5J	5 1/4	3/4	11 3/4	12	16	40	10	45	14	45	18	50	22
184T	5J	5 1/4	3/4	11 3/4	12	17	40	10	45	14	45	18	50	22
213T	6J	5 1/4	7/8	11 3/4	12	19	40	10	45	14	50	18	55	22
215T	6J	5 1/4	7/8	11 3/4	12	20	45	10	45	14	50	18	55	22
254T	7S	6 1/4	1	12 3/4	15	24	45	10	50	14	55	18	60	22
256T	8S	6 1/4	1 1/8	12 3/4	15	25	45	10	50	14	55	18	60	22
284T	8S	7	1 1/8	13 1/2	15	25	50	10	50	14	55	18	60	22
286T	8S	7	1 1/8	13 1/2	15	28	50	10	50	14	55	18	60	22
324T	8S	8	1 1/8	14 1/2	18	29	50	10	55	14	60	18	60	22
326T	8S	8	1 1/8	14 1/2	18	31	50	10	55	14	60	18	60	22
364T	8S	9	1 1/8	15 1/2	18	32	50	10	55	14	60	18	60	22

NOTES

All dimensions in inches. May vary ± 1/4 inches.
 *C Dimension varies depending on motor enclosure type. Max Dimension Listed
 Not for construction purposes unless certified.
 ROTATION: Clockwise when viewed from driver end.



MTH PUMPS

401 West Main Street • Plano, IL 60545-1436
 Phone: 630-552-4115 • Fax: 630-552-3688
 Email: SALES@MTHPUMPS.COM
 http://WWW.MTHPUMPS.COM



WARNING:
 CANCER AND REPRODUCTIVE HARM -
 WWW.P65WARNINGS.CA.GOV